

### INSTALLATION INSTRUCTIONS ADAPTER COUPLING

P/N'S 9942-00-0016-00, 9942-00-0025-00 & 9942-00-0098-00

#### IMPORTANT

**For use on:**

Polyethylene (PE) gas pipe meeting the requirements of ASTM D 2513

**Pressure Rating:** Designed to meet or exceed pressure rating of PE pipe per 49 CFR Part 192 and ASTM D 2513

**Operating Temperature:** -20 to 140° F

**Material:** Carbon Steel

#### THREADED END

1. APPLY A GOOD GRADE OF THREAD SEALANT OR LUBRICANT TO THREADS.
2. TIGHTEN JOINT LEAK TIGHT.

#### PE COMPRESSION END

3. CUT PE PIPE ENDS SQUARE, DEBURR INSIDE AND OUTSIDE, CLEAN THOROUGHLY TO ASSURE THERE IS NO DIRT, GREASE, OIL, ETC. ON ASSEMBLY AREA OF PIPE.
4. MARK STAB LENGTH ON PE PIPE (SEE EXAMPLE FOR CORRECT SIZE AND CORRESPONDING STAB LENGTH).

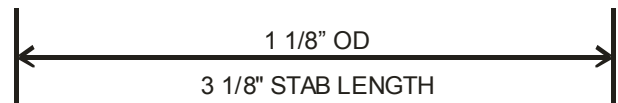

5. LOOSEN COMPRESSION NUT AND INSERT PE PIPE UNTIL IT BOTTOMS IN COUPLING.
6. TIGHTEN COMPRESSION NUT UNTIL IT SHOULDERS AGAINST THE COUPLING. LINE MARKED FOR STAB LENGTH SHOULD BE NO MORE THAN 7/16" FROM FACE OF NUT, IF NOT, REASSEMBLE.
7. TO ASSURE PROPER ASSEMBLY AND TO COMPLY WITH 49 CFR 192 SUBPART J—TEST REQUIREMENTS, THE JOINT SHALL BE LEAK TESTED.

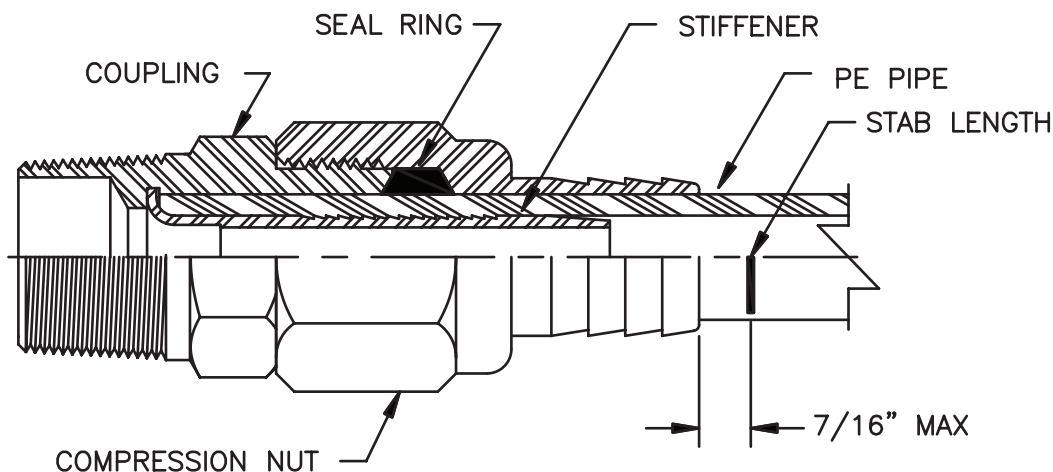

ECN 2625 REV "F" 08/25/14